

FUSELAGE TOP VIEW

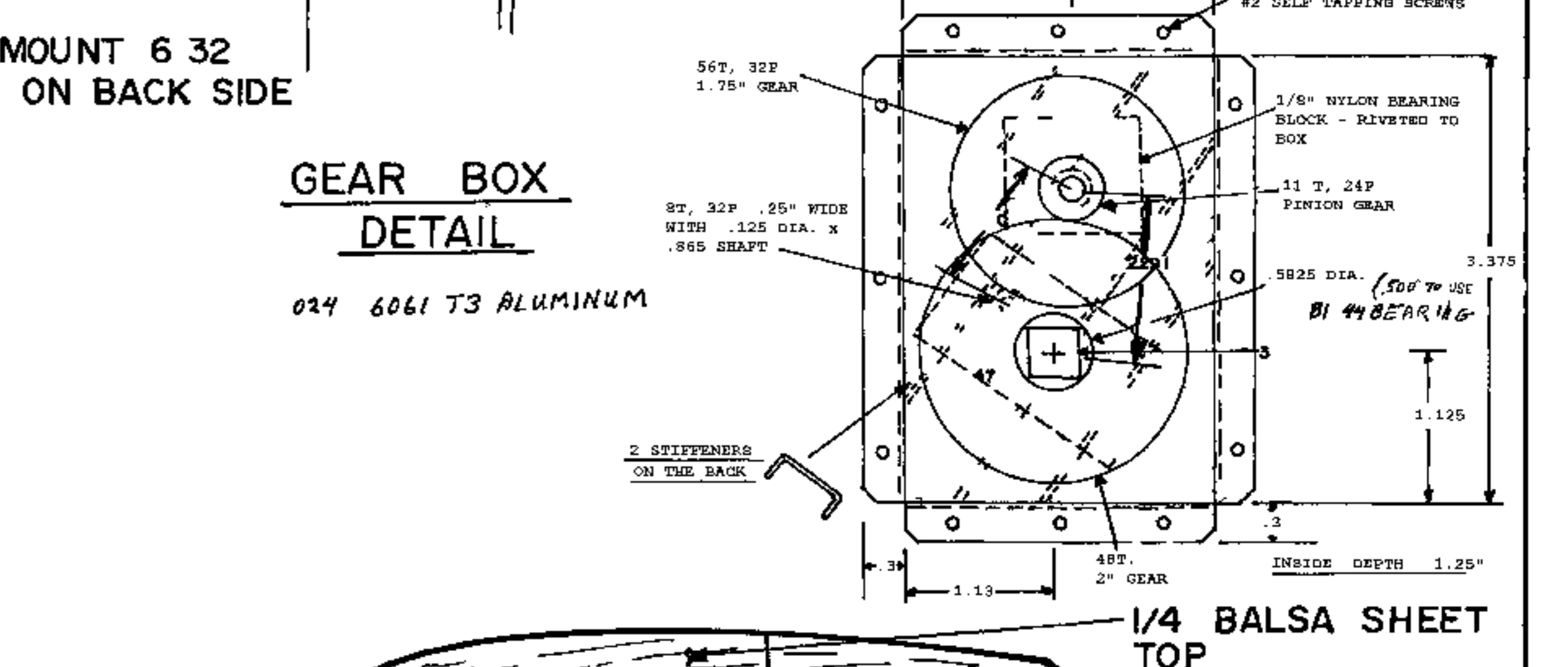

FUSELAGE SIDE VIEW

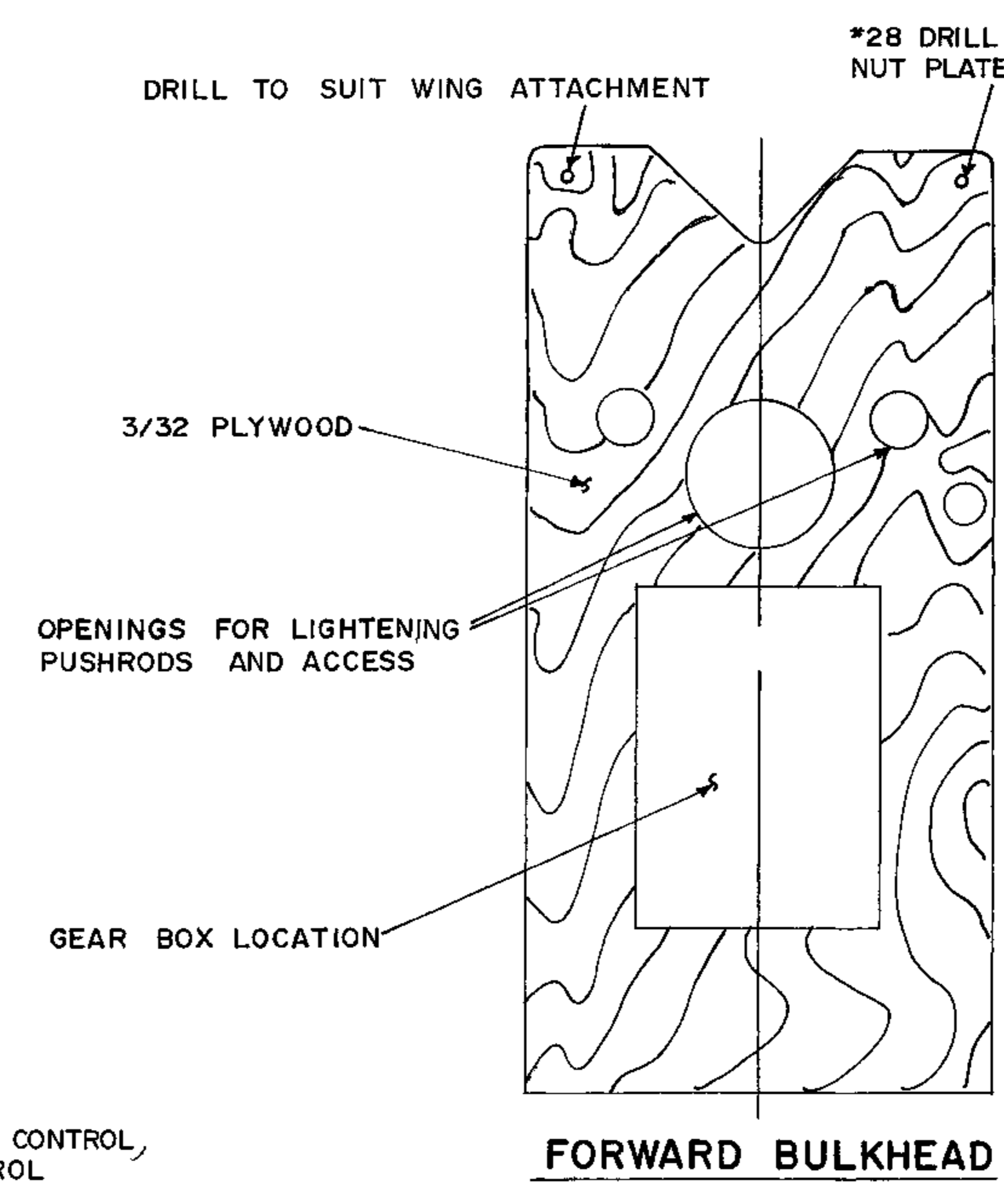
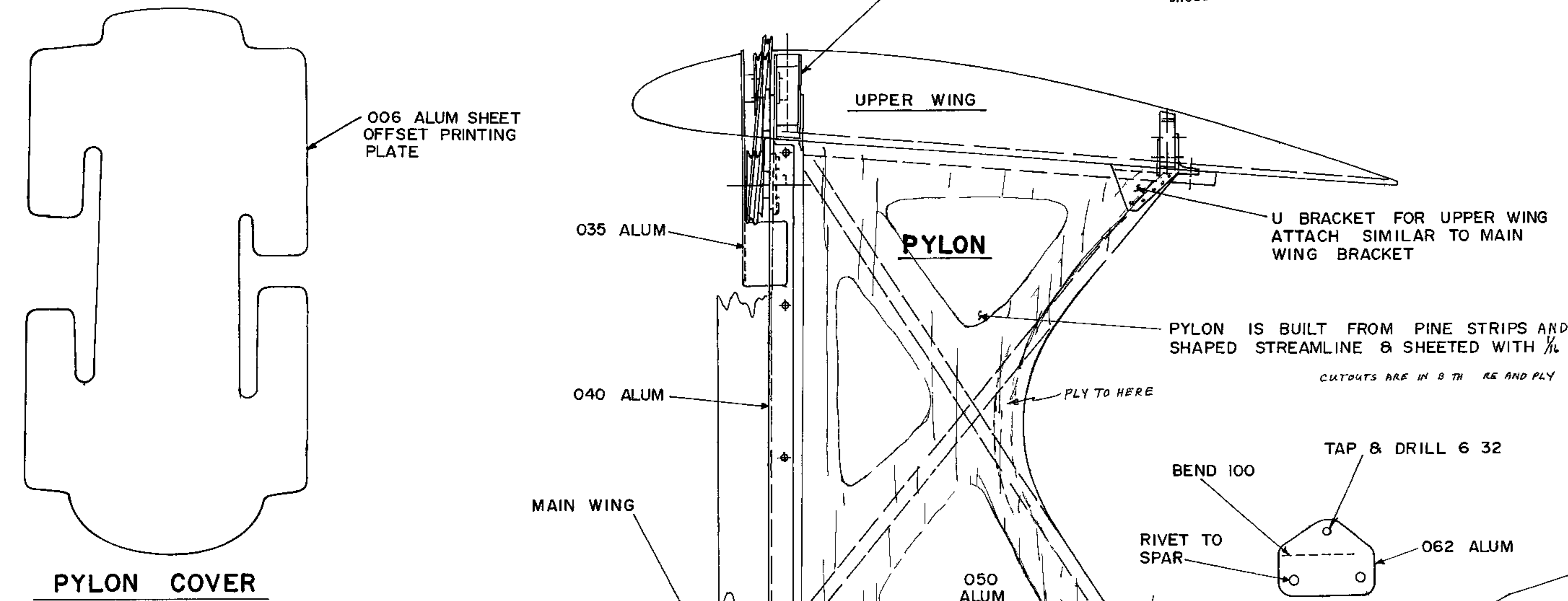
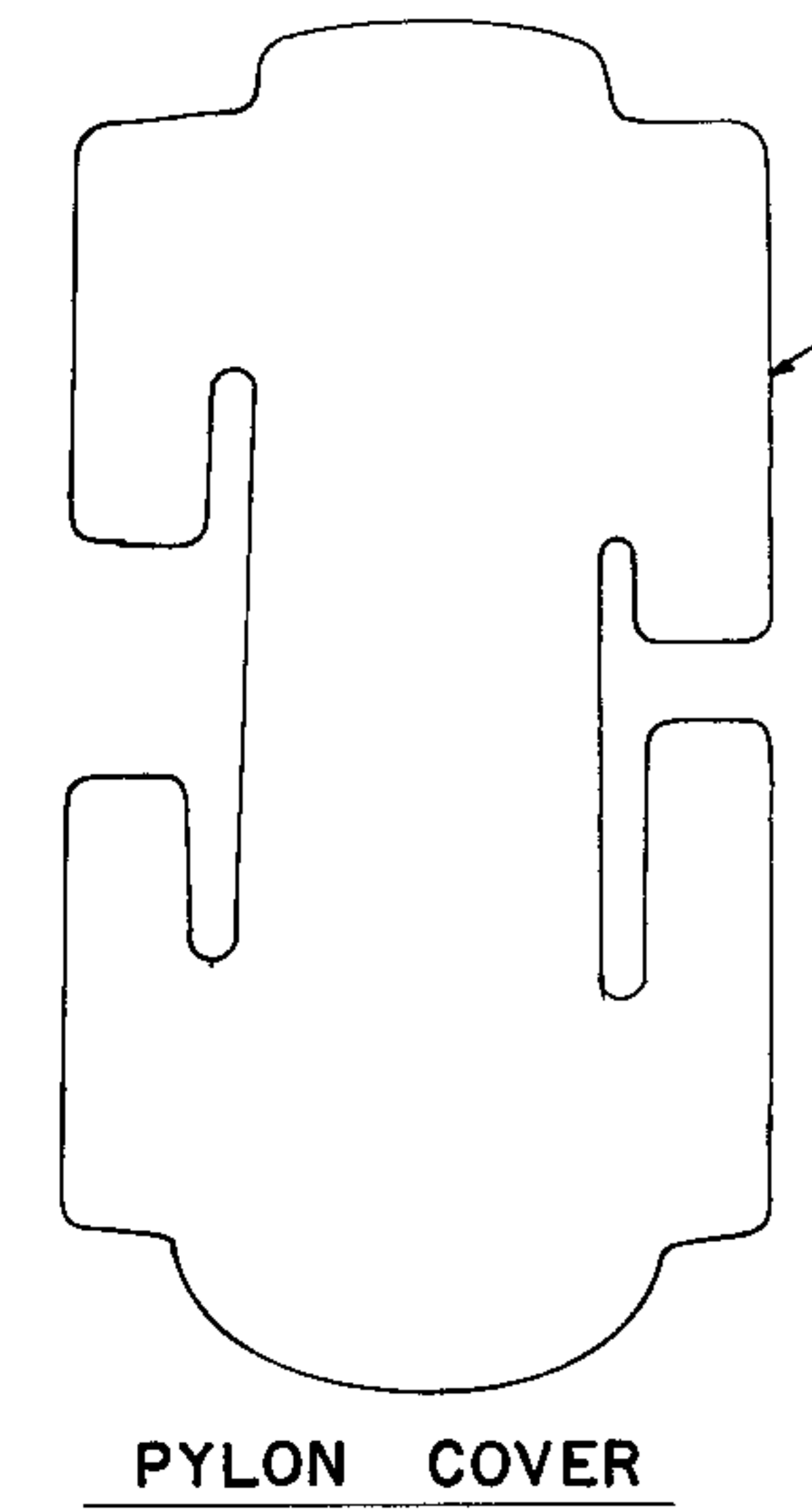



GROSS WEIGHT	7 LBS 7 OZ
ENGINE	K B 35 (8 OZ)
WING ASSEMBLY & DRIVE MECH	2 LBS 12 OZ
FUSE TAIL SURFACES	2 LBS 13 OZ
TANK	7 OZ
NOSE CONE	NOT LISTED
RADIO SERVOS ETC	2 5 OZ
FAN FLYWHEEL	6 5 OZ
GEAR BOX	

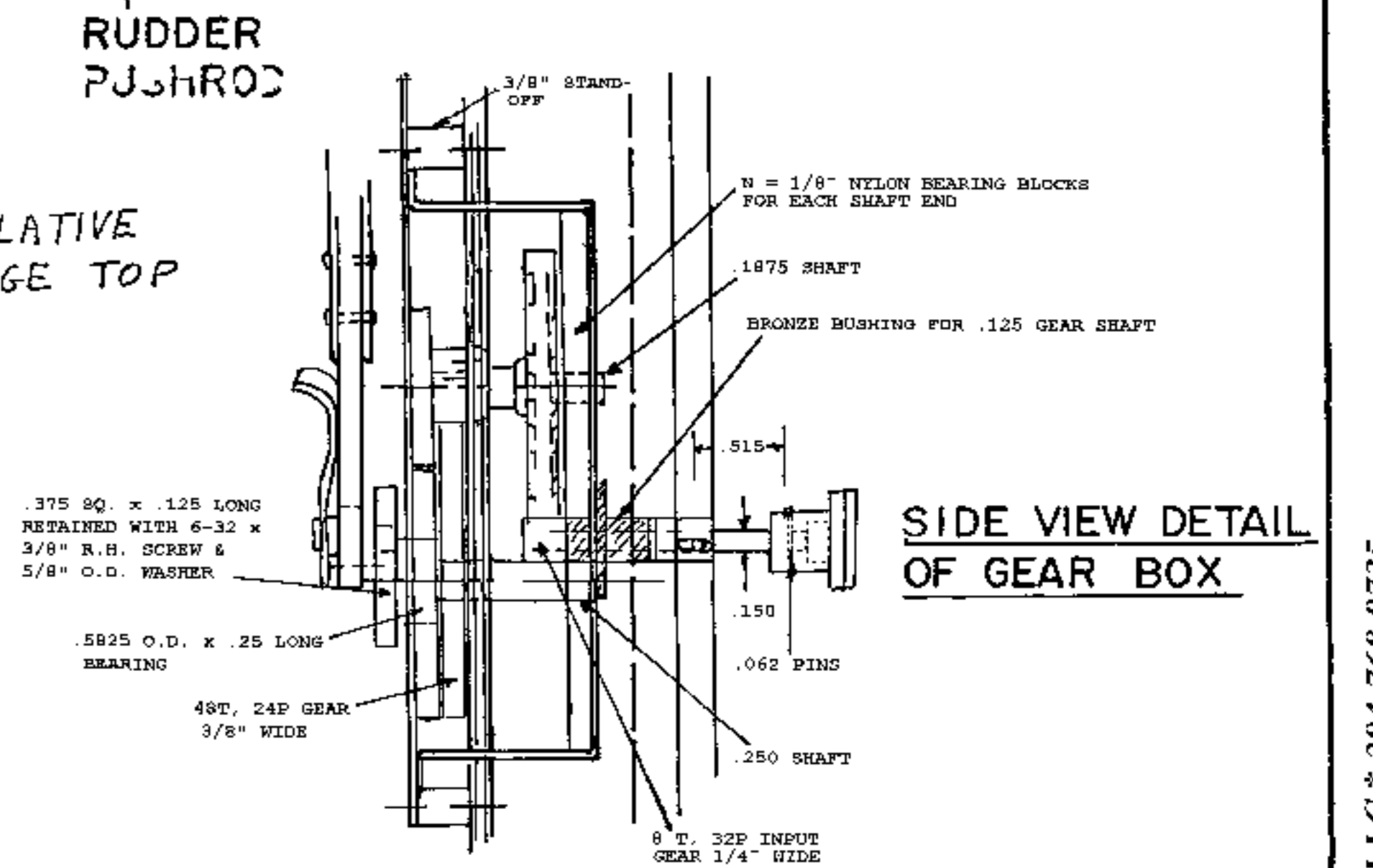

NOTE THIS MODEL WAS DESIGNED AND BUILT IN 1961 BY PERCIVAL H SPENCER. MANY OF THE MECHANICAL PARTS MUST BE HAND MADE UNLESS MANUFACTURED PARTS CAN BE FOUND. THE TEXT MUST BE STUDIED CAREFULLY IN ORDER TO BUILD THE MODEL AS MANY OF THE PARTS ARE VITAL AND MUCH CAN BE BUILT USING MORE MODERN METHODS. THESE 3 INKED PLANS WERE DRAWN FROM SPENCE'S ORIGINAL ONE PAGE PLAN.



MODEL AIRPLANE NEWS
SPENCE'S ORNIPLANE
 DESIGNED BY PERCIVAL H SPENCER
 REVIEWED BY JACK STEPHENSON
 INKED PLANS BY JOE DEMARCO
 SHEET 1 OF 3
 ALL RIGHTS RESERVED
 FSP

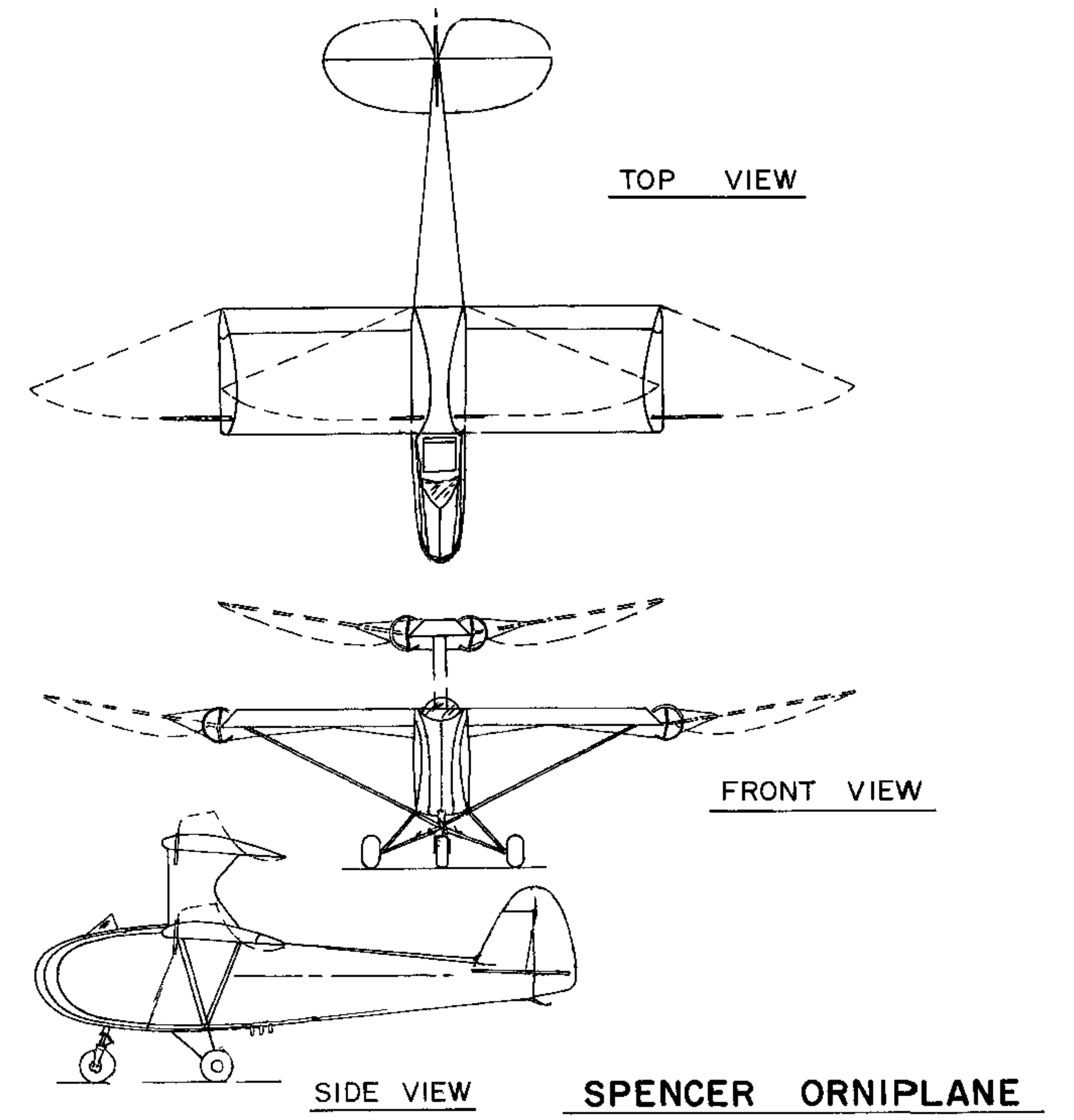
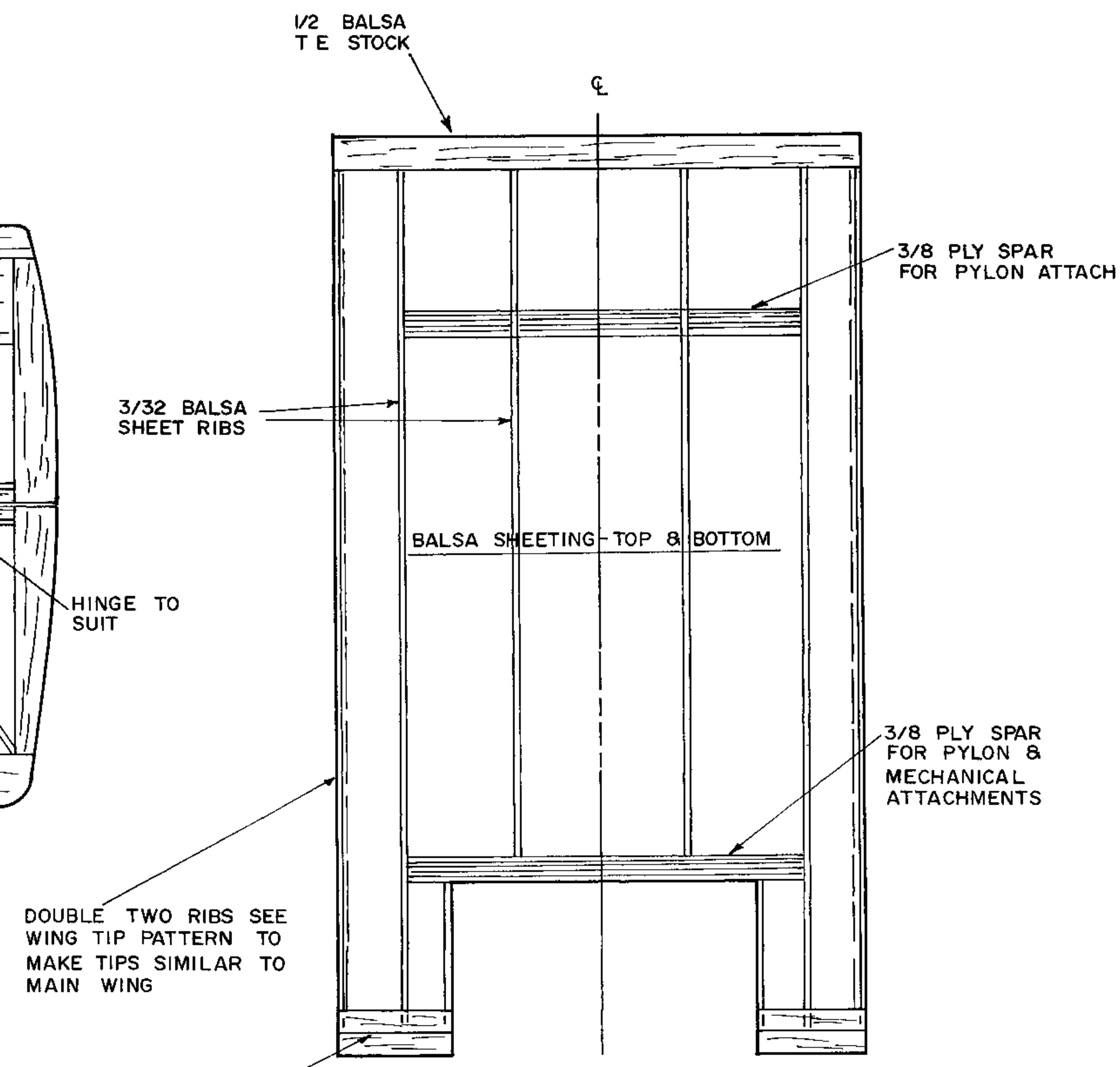
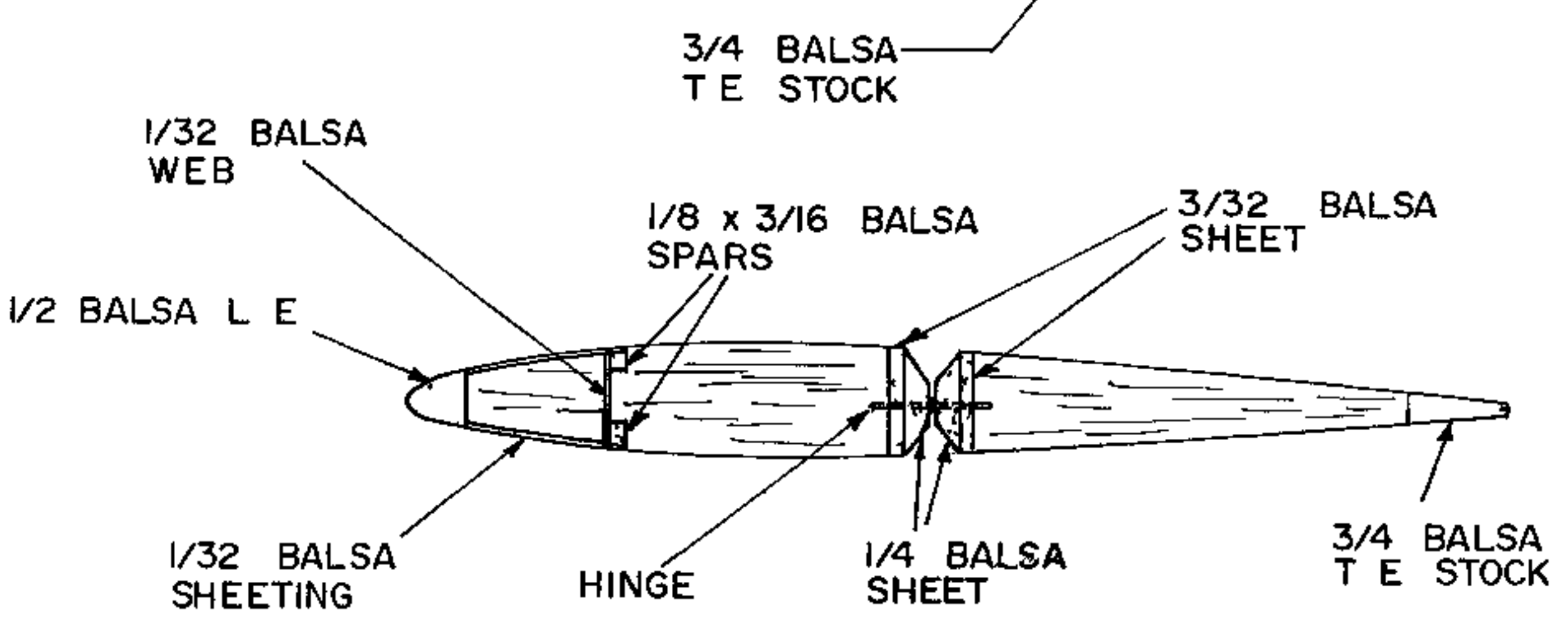
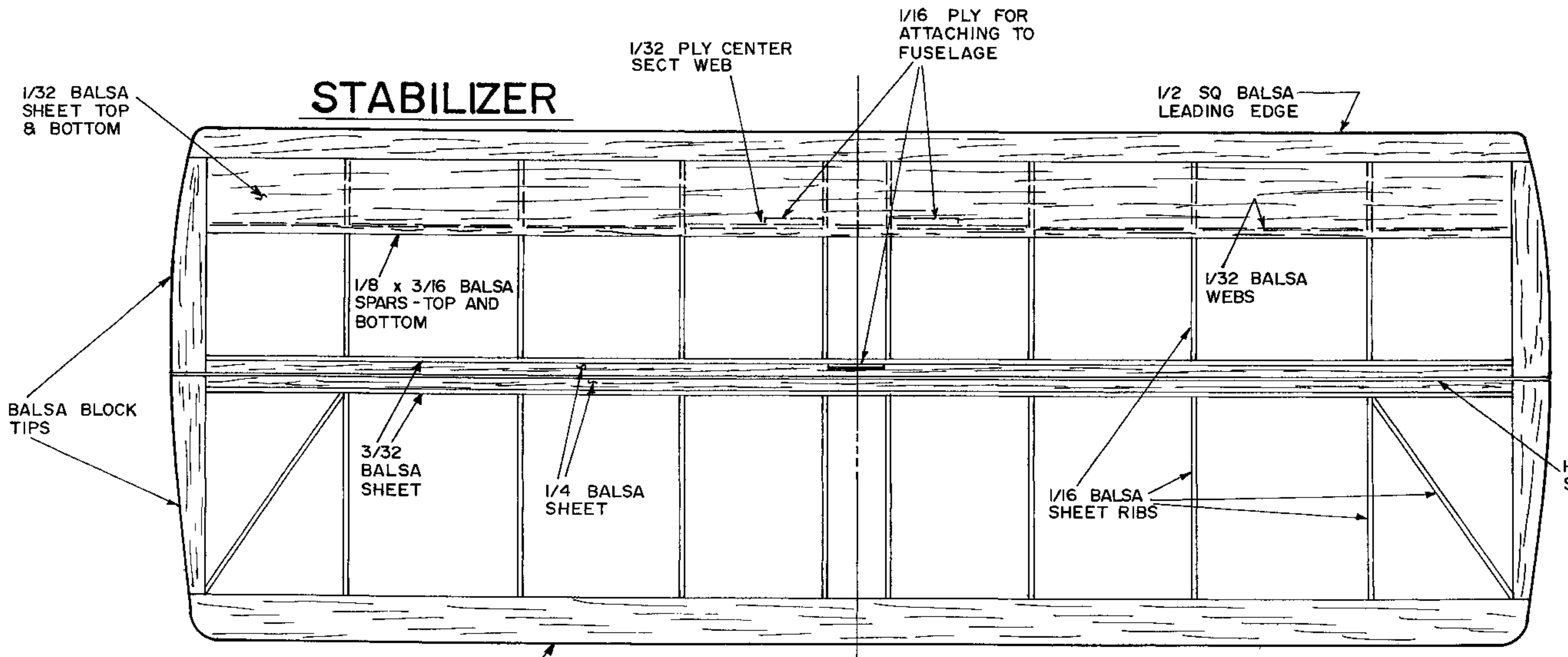
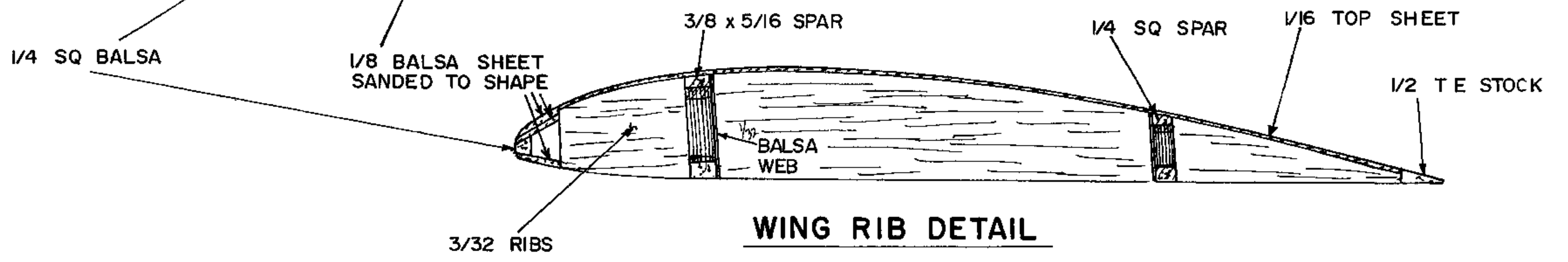


MODEL AIRPLANE NEWS
SPENCE'S ORNIPLANE
 DESIGNED BY PERCIVAL H SPENCER
 REVIEWED BY JACK STEPHENSON
 INKED PLANS BY JOE DEMARCO
 ALL RIGHTS RESERVED